

100/40 Gbps Ethernet - Are you ready?



PMD LAYER

The **Physical Medium Dependent** sublayer or **PMD** defines the details of transmission and reception of individual bits on the physical medium. The PMD layer interfaces with the PMA layer and translates the encoded data to and from signals suitable for the physical medium. The PMA continuously sends parallel bit streams to the PMD, one per lane. The PMD converts these streams of bits into separate optical signal streams; the optical signal streams are then wavelength division multiplexed and delivered to the Medium Dependent Interface (MDI).

CFP Types

	40GBase-LR4	100GBase-SR10	100GBase-LR4	100GBase-ER4	10x10 - 2 km	10x10 - 10 km	10x10 - 40 km
Standard	IEEE 802.3ba	IEEE 802.3ba	IEEE 802.3ba	IEEE 802.3ba	10x10 MSA	10x10 MSA	10x10 MSA
Wavelength	1310 nm WDM ITU-T G.694.2	850 nm (10 fiber pairs)	1310 nm WDM ITU-T G.694.1	1310 nm WDM ITU-T G.694.1	1550 nm WDM	1550 nm WDM	DWDM ITU-T G.694.1
Reach	10 km	150 m	10 km	40 km	2 km	10 km	40 km
Optical rate	4 x 10 Gbps	10 x 10 Gbps	4 x 25 Gbps	4 x 25 Gbps	10 x 10 Gbps	10 x 10 Gbps	10 x 10 Gbps

WDM Lane Assignments

Lane	Center Wavelength (nm)		Center Frequency (THz)								
	40GBase-LR4	100GBase-LR4 100GBase-ER4	10x10 MSA - 40 km								
			Band 1	Band 2	Band 3	Band 4	Band 5	Band 6	Band 7	Band 8	
L0	1271	1295.56	1523	196.10	195.00	193.90	192.80	196.05	194.95	193.85	192.75
L1	1291	1300.05	1531	196.00	194.90	193.80	192.70	195.95	194.85	193.75	192.65
L2	1311	1304.58	1539	195.90	194.80	193.70	192.60	195.85	194.75	193.65	192.55
L3	1331	1309.14	1547	195.80	194.70	193.60	192.50	195.75	194.65	193.55	192.45
L4	n/a	n/a	1555	195.70	194.60	193.50	192.40	195.65	194.55	193.45	192.35
L5	n/a	n/a	1563	195.60	194.50	193.40	192.30	195.55	194.45	193.35	192.25
L6	n/a	n/a	1571	195.50	194.40	193.30	192.20	195.45	194.35	193.25	192.15
L7	n/a	n/a	1579	195.40	194.30	193.20	192.10	195.35	194.25	193.15	192.05
L8	n/a	n/a	1587	195.30	194.20	193.10	192.00	195.25	194.15	193.05	191.95
L9	n/a	n/a	1595	195.20	194.10	193.00	191.90	195.15	194.05	192.95	191.85

CFP Options

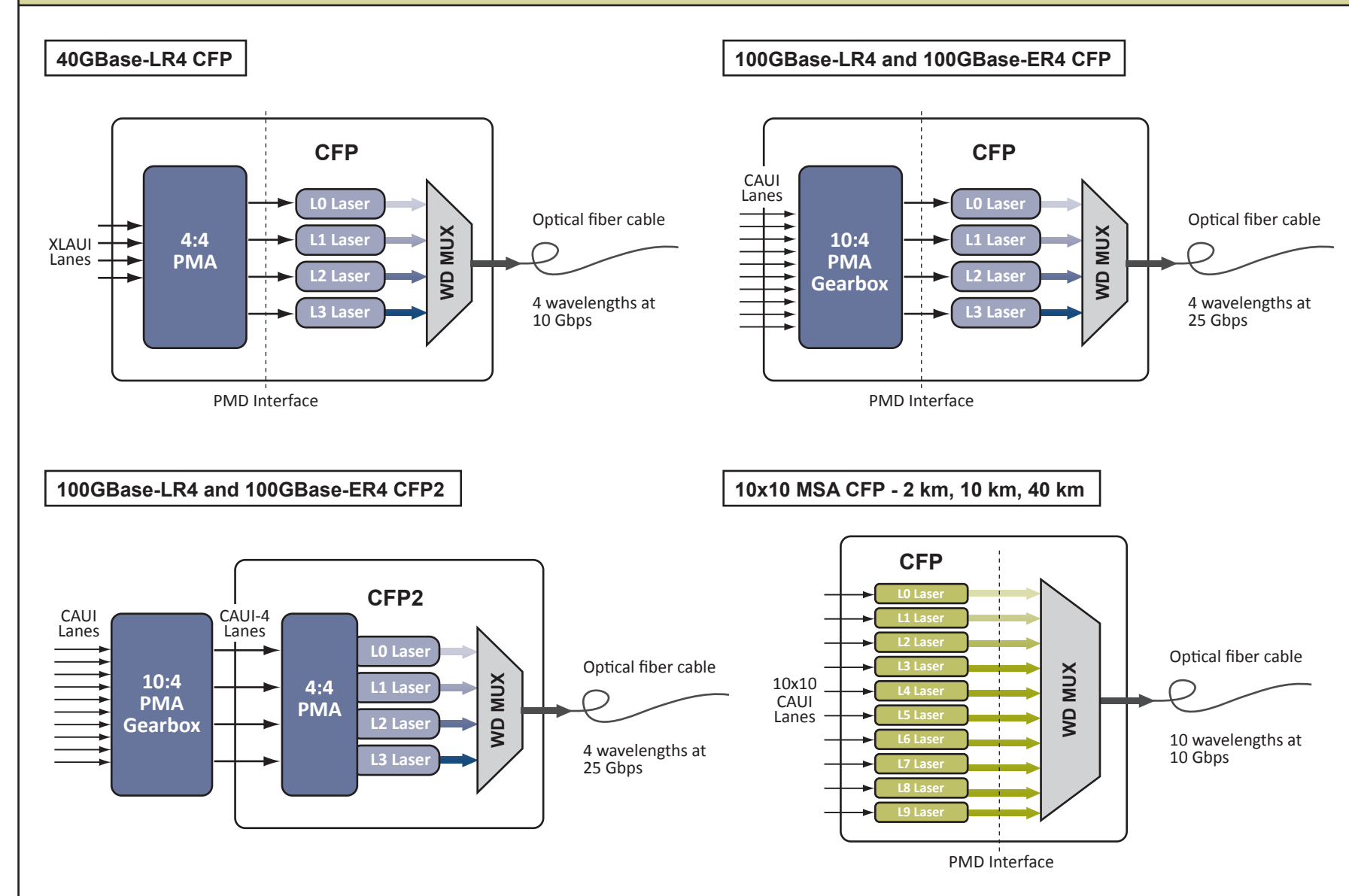

IEEE 802.3ba STANDARD

Protocol Stack

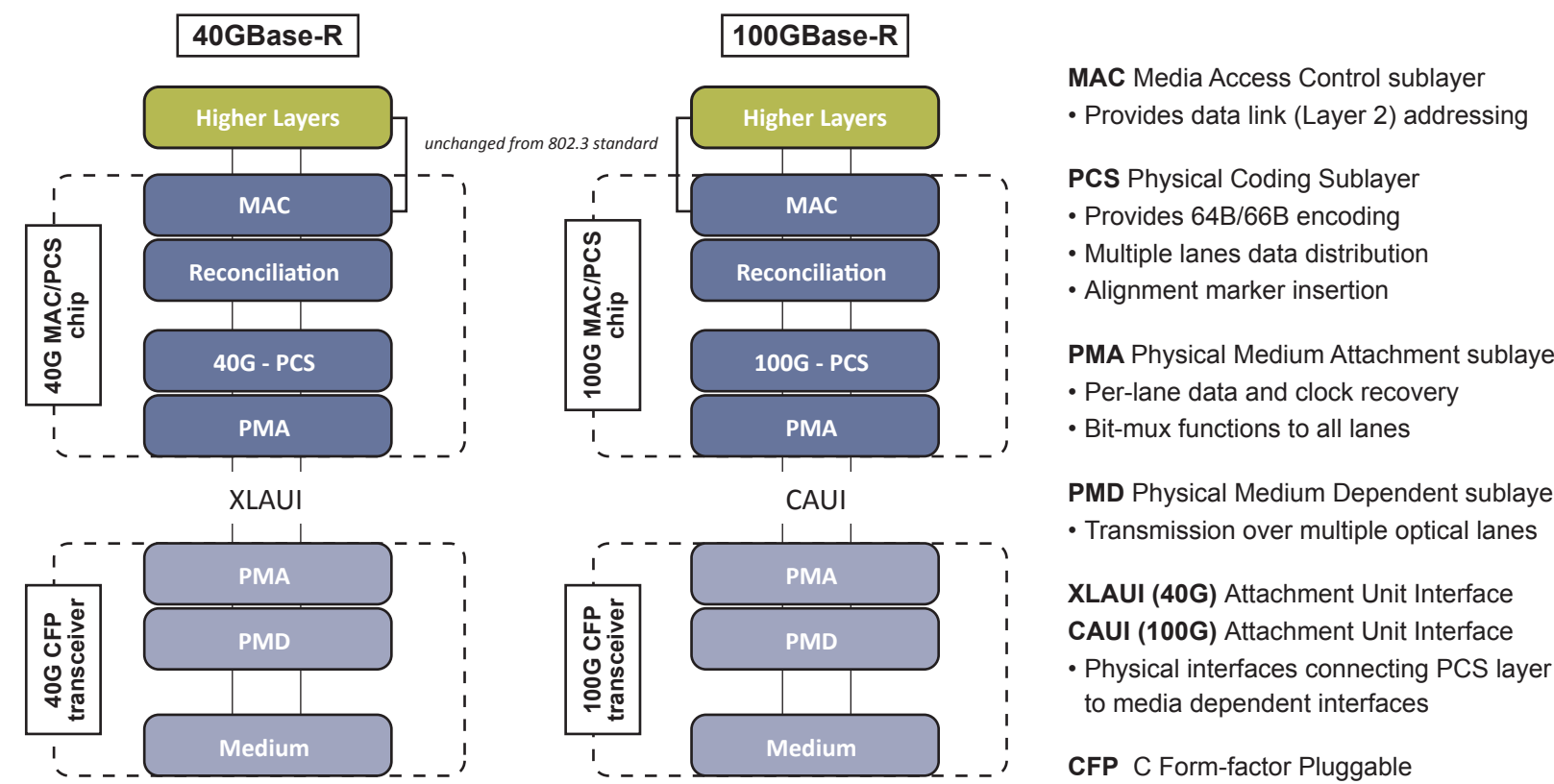

MAC Media Access Control sublayer
• Provides data link (Layer 2) addressing

PCS Physical Coding Sublayer
• Provides 64B/66B encoding
• Multiple lanes data distribution
• Alignment marker insertion

PMA Physical Medium Attachment sublayer
• Per-lane data and clock recovery
• Bit-mux functions to all lanes

PMD Physical Medium Dependent sublayer
• Transmission over multiple optical lanes

XLAUI (40G) Attachment Unit Interface
CAUI (100G) Attachment Unit Interface
• Physical interfaces connecting PCS layer to media dependent interfaces

CFP C Form-factor Pluggable

THE BIG PICTURE

100GBase-R

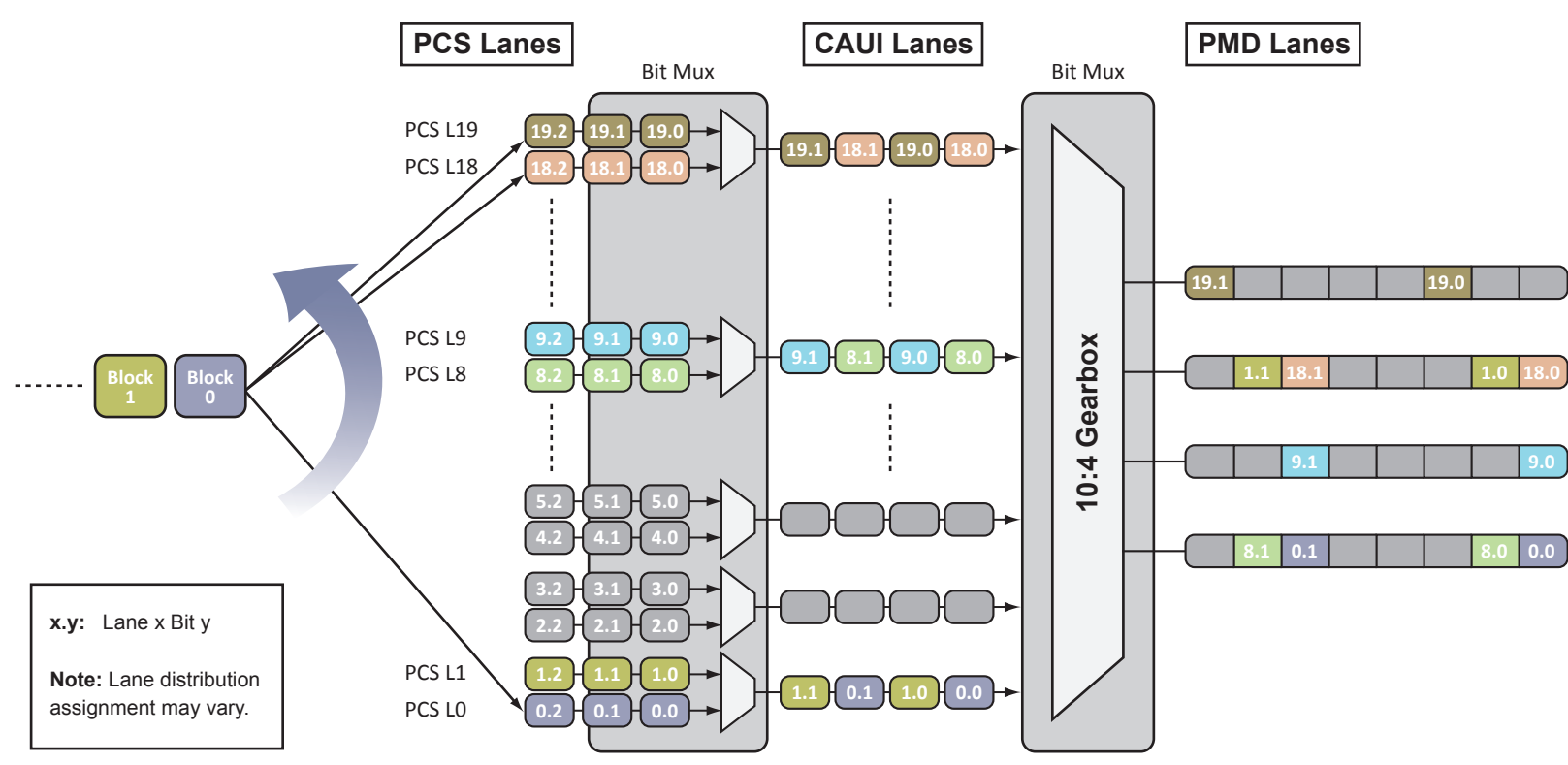

PMA LAYER

The **Physical Medium Attachment** sublayer or **PMA** allows the PCS to connect in a media-independent way with a range of physical media. It uses bit level multiplexing to adapt the PCS lanes to the appropriate number of physical lanes required by the PMD interface.

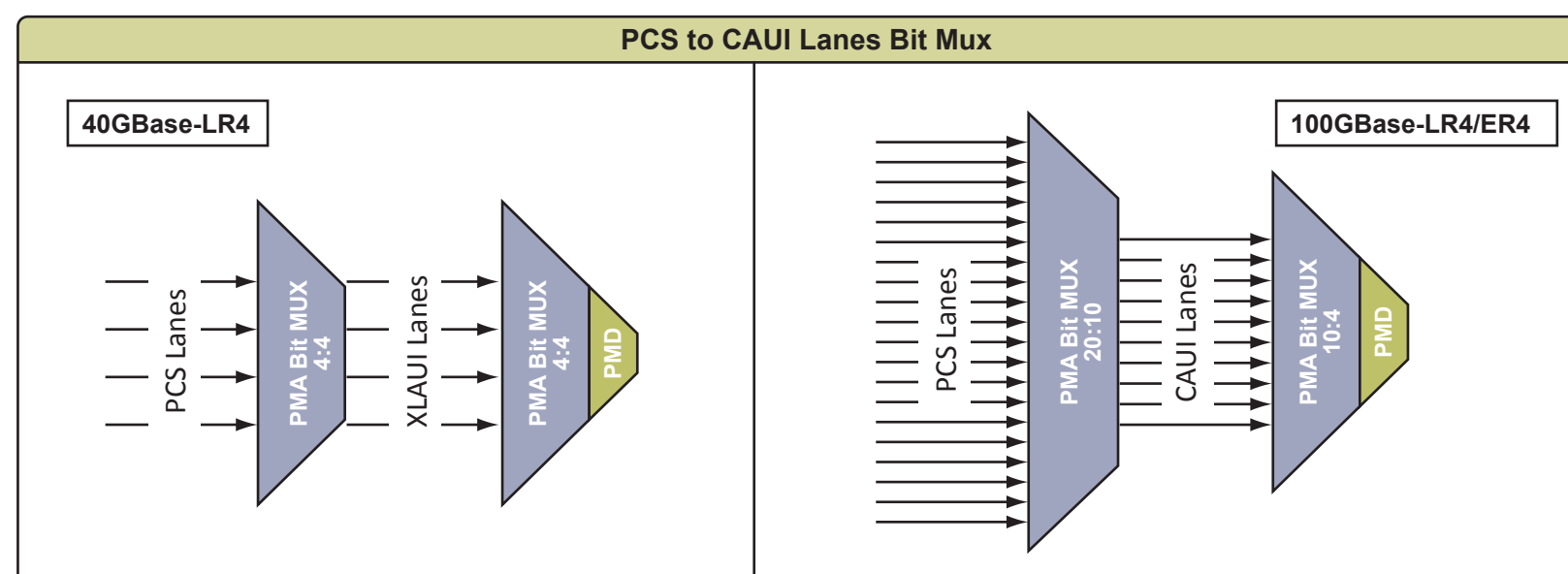

PCS LAYER

The **Physical Coding Sublayer (PCS)** shields upper layers (MAC) from the specific nature of the underlying channel. Both 40GBase-R and 100GBase-R are based on a 64B/66B code which supports transmission of data and control characters, while maintaining robust error detection. When communicating with the lower layer (PMA), the PCS uses multiple serial streams or PCS lanes.

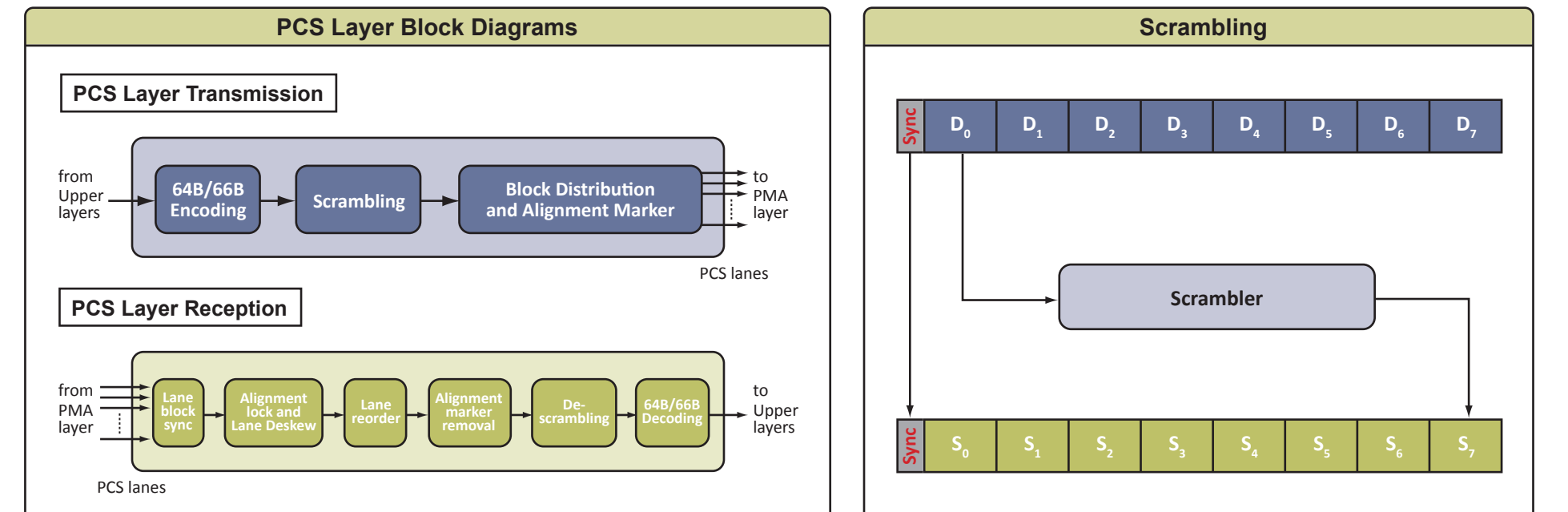

Input Data		Block Payload	Block Type Field	
Bit Position	0 1	2 ... 65	C ₀	C ₁ C ₂ C ₃ C ₄ C ₅ C ₆ C ₇
Data Block Format	01	D ₀ D ₁ D ₂ D ₃ D ₄ D ₅ D ₆ D ₇	0x78	D ₀ D ₁ D ₂ D ₃ D ₄ D ₅ D ₆ D ₇
Control Block Formats	10	O ₀ D ₀ D ₁ D ₂ Z ₀ Z ₁ Z ₂ Z ₃	0x4B	D ₀ D ₁ D ₂ D ₃ O ₀
	10	T ₀ C ₀ C ₁ C ₂ C ₃ C ₄ C ₅ C ₆ C ₇	0x87	C ₀ C ₁ C ₂ C ₃ C ₄ C ₅ C ₆ C ₇
	10	D ₀ T ₀ C ₀ C ₁ C ₂ C ₃ C ₄ C ₅ C ₆ C ₇	0x99	D ₀
	10	D ₀ D ₁ T ₀ C ₀ C ₁ C ₂ C ₃ C ₄ C ₅ C ₆ C ₇	0xA4	D ₀ D ₁ D ₂ D ₃ C ₀ C ₁ C ₂ C ₃ C ₄ C ₅ C ₆ C ₇
	10	D ₀ D ₁ D ₂ D ₃ T ₀ C ₀ C ₁ C ₂ C ₃ C ₄ C ₅ C ₆ C ₇	0xCC	D ₀ D ₁ D ₂ D ₃ D ₄ D ₅ D ₆ D ₇ C ₀ C ₁ C ₂ C ₃ C ₄ C ₅ C ₆ C ₇
	10	D ₀ D ₁ D ₂ D ₃ D ₄ T ₀ C ₀ C ₁ C ₂ C ₃ C ₄ C ₅ C ₆ C ₇	0xD2	D ₀ D ₁ D ₂ D ₃ D ₄ D ₅ D ₆ D ₇ C ₀ C ₁ C ₂ C ₃ C ₄ C ₅ C ₆ C ₇
	10	D ₀ D ₁ D ₂ D ₃ D ₄ D ₅ T ₀ C ₀ C ₁ C ₂ C ₃ C ₄ C ₅ C ₆ C ₇	0xE1	D ₀ D ₁ D ₂ D ₃ D ₄ D ₅ D ₆ D ₇ C ₀ C ₁ C ₂ C ₃ C ₄ C ₅ C ₆ C ₇
	10	D ₀ D ₁ D ₂ D ₃ D ₄ D ₅ D ₆ T ₀ C ₀ C ₁ C ₂ C ₃ C ₄ C ₅ C ₆ C ₇	0xFF	D ₀ D ₁ D ₂ D ₃ D ₄ D ₅ D ₆ D ₇

Input Data		Block Payload	Block Type Field	
Bit Position	0 1	2 ... 65	M ₀	M ₁ M ₂ BIP ₃ M ₄ M ₅ M ₆ BIP ₇

Input Data		Block Payload	Block Type Field	
Bit Position	0 1	2 ... 65	M ₀	M ₁ M ₂ BIP ₃ M ₄ M ₅ M ₆ BIP ₇

